

Panasonic

ideas for life

Super Dynamic II
Color Dome Camera
with Low-Light B/W Mode
WV-CS854B



THE MOST ADVANCED DOME CAMERA SYSTEM AVAILABLE!

Panasonic's new WV-CS854B Unitized Color Dome Camera is the most advanced color dome camera system available. It features our exclusive **Super Dynamic II** technology and Day/Night operation, plus a long list of advanced features designed to provide optimum performance under virtually any lighting condition. The all-in-one unit incorporates a 1/4-type color CCD camera, 22x zoom lens, and rotating chassis packed in a sleek 110mm (4.3") diameter housing ideal for almost any location.

WV-CS854B's **Super Dynamic II** capabilities give the WV-CS854B a dynamic range 64 times greater than conventional cameras to provide excellent images in even under highly contrasted lighting conditions. In addition, the WV-CS854B delivers color images in light as low as 1lux (0.1fc), and black and white images in as little as 0.06lux (0.006fc) of light. It's the ideal camera for surveillance around the clock in areas affected by changing light conditions. With its full 360° horizontal rotation, 190° vertical pan, and 300°/second speed, surveillance of any subject is constant and continuous. Privacy Zone Masking and Patrol Learn features also make the WV-CS854B perfect for even the most demanding surveillance applications. In addition, the unit incorporates digital motion detection for advanced alarm applications and an "image hold" function to minimize image distortion during fast motion transitions.

The Panasonic WV-CS854B — it's the most advanced dome camera system available!

KEY FEATURES

- Compact 110mm (4.3") diameter dome all-in-one color unit.
- **Super Dynamic II** technology delivers 64x wider dynamic range compared to conventional cameras.
- 510 lines of horizontal resolution (at High position).
- Digital-FLIP by memory read out allows automatic 190-degree turn.
- Day/Night operation to automatically or manually select color or B/W image capture by setup menu.
- Minimum illumination of,
1 lux (0.1 fc) at color imaging (Sens up off: AGC High)
0.06 lux (0.006 fc) at B/W imaging (Pix Sens up off: Sens up off: AGC High)
0.03 lux (0.003 fc) at B/W imaging (Pix Sens up on: Sens up off: AGC High)
- Privacy zone masking function.
- Linear 32x electronic sensitivity enhancement function.
- Digital motion detector.
- Patrol Learn function.
- Auto panning function with 64 preset positions.
- 360° panning and speed of max. 300°/s at preset mode.
- Image hold function during panning.
- 22x optical zoom lens (3.79 - 83.4mm at F1.6) plus 10x electronic digital zoom for total zoom capacity of 220x.
- Auto focus lens.
- Multiplex-coaxial or RS485 data communication.
- Four (4) alarm inputs and two (2) outputs terminals.
- 16 alphanumeric character display.
- Internal/Line-lock/Multiplexed Vertical Drive (VD2) synchronization.
- 24V AC, 60Hz power source.
- Optional smoked and mirror type dome covers are available.

PRODUCT CONSTRUCTION

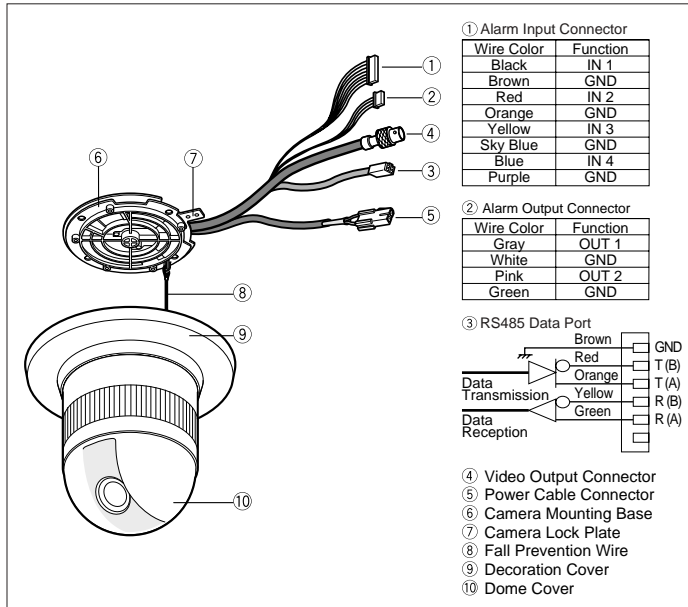

APPEARANCE

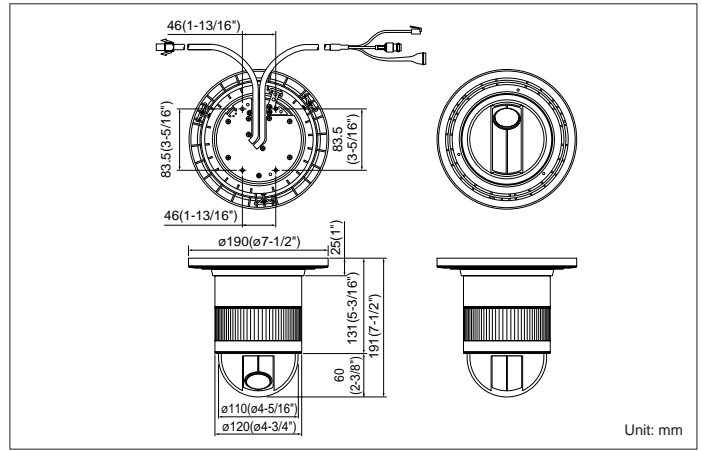

SPECIFICATIONS

Model No.	WV-CS854B
Effective Pixels	768 (H) x 494 (V)
Scanning Area	3.65 mm (H) x 2.74 mm (V), 1/4-type Super Dynamic II CCD
Synchronization	Internal / Line-lock / Multiplexed Vertical Drive (VD2)
Horizontal Scanning Frequency	15.734 kHz
Vertical Scanning Frequency	59.94 Hz
Video Output	1.0 V [p-p] NTSC/EIA composite / 75 Ω
Horizontal Resolution	480 lines at center (Color at normal), 510 lines at center (Color at High), 570 lines at center (B/W)
Vertical Resolution	350 lines at center
Signal-to-Noise Ratio	50 dB (AGC OFF, weight on)
Dynamic Range	48 dB (Super Dynamic II ON)
Minimum Illumination	1 lux (0.1 fc) at color imaging (Sens up off: AGC High) 0.06 lux (0.006 fc) at B/W imaging (Pix Sens up off: Sens up off: AGC High) 0.03 lux (0.003 fc) at B/W imaging (Pix Sens up on: Sens up off: AGC High)
Zoom Speed	approx. 4.5 s (TELE / WIDE) in manual mode
Focus Speed	approx. 5 s (FAR / NEAR) in manual mode
Iris	automatic (open / close is possible) / manual
Maximum Aperture Ratio	1:1.6 (WIDE) - 3.0 (TELE)
Focal Length	3.79 - 83.4 mm
Angular Field of View	H 2.6° - 52.3° V 2.0° - 39.9°
Electronic Shutter	1/60 (OFF), AUTO 1/100, 1/250, 1/500, 1/1,000, 1/2,000, 1/4,000, 1/10,000 s
AGC	ON (LOW) / ON (MID) / ON (HIGH) / OFF
Sens Up	MAX. 32 times, AUTO / FIX
Super Dynamic II	selectable ON / OFF (SETUP MENU)
Zoom Ratio	x22 + digital zoom x10
Iris Range	F1.6 - 22, CLOSE
Auto Focus	MANUAL / AUTO
Auto Mode	OFF / SEQ / SORT / AUTO PAN / PATROL
Auto Pan Key	SEQ / SORT / AUTO PAN / PATROL PLAY
Digital Flip	ON / OFF
Camera ID	preset ID, camera ID, area title: up to 16 characters
Motion Detector	ON / OFF
Alarm IN	4 inputs (ALARM IN 1 - 4)
Alarm OUT	2 outputs (ALARM / AUX1, B/W / AUX2)
B/W Mode	AUTO / ON / OFF
Privacy Zone	ON / OFF, up to 8 zones
Proportional PAN / TILT	ON / OFF
Patrol	LEARN / PLAY / STOP, up to 60 seconds
Cleaning	ON / OFF
Panning Range	360° endless
Panning Angle Setting	possible (in auto-pan mode)
Panning Mode	manual / sequential position / sort position / auto pan
Panning Speed	manual: approx. 0.1°/s - 120°/s 8-steps / 64-steps sequential position: maximum approx. 300°/s
Tilting Range	-5° ~ 185°
Tilting Mode	manual / sequential position / sort position
Tilting Speed	manual: approx. 0.1°/s - 120°/s 8-steps / 64-steps sequential position: maximum approx. 300°/s
Controls	pan / tilt, lens, 64 preset positions, home position
Power Source	24V AC, 60 Hz
Power Consumption	13W
Ambient Operating Temperature	-10°C ~ +50°C (14°F ~ 122°F)
Dimensions	ø120 (D) x 191 (H) mm [ø4-3/4" (D) x 7-1/2" (H)]
Weight	approx. 2 kg (4.4 lbs.)

SYSTEM EXAMPLE

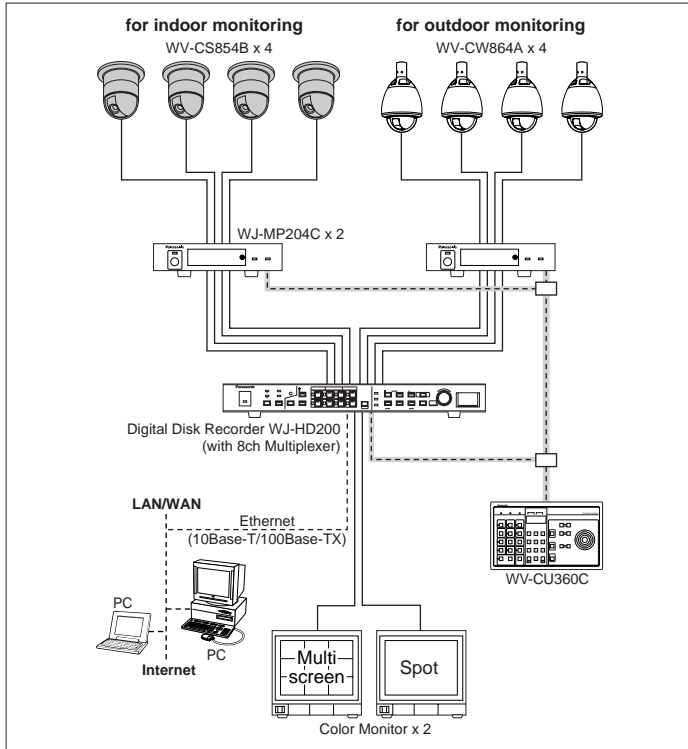

OPTIONAL ACCESSORIES



• Weights and dimensions are approximate. • Specifications are subject to change without notice. • These products may be subject to export control regulations.

Panasonic

Panasonic Digital Communications & Security Company
Unit of Matsushita Electric Corporation of America

Security Systems Group
<http://www.panasonic.com/cctv>

Executive Office : One Panasonic Way 3E-7, Secaucus, New Jersey 07094
Zone Office
Eastern : One Panasonic Way, Secaucus, NJ 07094 (201) 348-7303
Central : 1707 N.Randal Road, Elgin, IL 60123 (847) 468-5205
Western : 6550 Katella Ave., Cypress, CA 90630 (714) 373-7840

DISTRIBUTED BY:

PANASONIC CANADA INC.
5770 Ambler Drive, Mississauga, Ontario, L4W 2T3 Canada (905) 624-5010
PANASONIC SALES COMPANY
DIVISION OF MATSUSHITA ELECTRIC OF PUERTO RICO, INC.
San Gabriel Industrial Park 65th Infantry Ave. KM. 9.5 Carolina, P.R. 00985 (809) 750-4300

Printed in Japan
WV-JHCS854BT(2P-470H)